

EATON | Fluid Power

M3000/S3000/SMD Series Cylinders

Medium Duty Cylinders for
a Wide Range of Applications

M3000
S3000
SMD (Special Medium Duty)



EFPA/210/1203/B



Sold and distributed by: Hyteco (Aust) Pty Ltd Tel: 61 (0)7 38813312

Contents

M3000 and S3000 Series

General Description	-----	2
Basic Specifications	-----	2
Features	-----	2
Installation Dimensions	-----	3
S3000 Screwed Cap Design	-----	4
Seal kits and Spare parts	-----	4
Theoretical Push and Pull Forces	-----	5
Model Code & Order Code	-----	6

SMD (Special Medium Duty) Series

General Description	-----	7
Basic Specifications	-----	7
Features	-----	7
Options	-----	7
Mounting Options	-----	8
Installation Dimensions		
No Mount and Tie Rod Tapping Mount	----	9
Rectangular Flange Mount	-----	10
Circular Flange Mount	-----	11
Accessories	-----	12
Model Code	-----	13
Seal Kits and accessories	-----	13

GENERAL DESCRIPTION

The Vickers M3000 and S3000 are hydraulic linear actuators suitable for a variety of applications in both mobile and industrial fields.

The compact design and simple but robust construction provide cost effective solutions, reliable operation and long service life.

BASIC SPECIFICATIONS

Maximum pressure

Bore size 2" to 3.5" (50.8mm to 88.9mm)	----	210 bar (3000 psi)
Bore size 4" to 5" (101.6 to 127mm)	-----	175 bar (2500 psi)

Bore sizes (inches)

M3000 Series	-----	2", 2.5", 3", 3.5", 4", 4.5", 5"
S3000 Series	-----	2", 2.5", 3", 3.5", 4"

Standard strokes (mm) ----- 203, 305, 406, 457, 610

Non-standard stroke cylinders are available on request, including strokes shorter than 203mm, or longer than 610mm.

GRAPHICAL SYMBOL

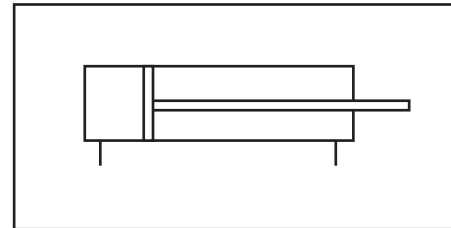

FEATURES

- Low cost units suitable for a wide range of mobile and industrial applications.
- 7 bore sizes from 2" to 5" for M3000 Series, and 5 sizes from 2" to 4" for S3000 Series.
- Cylinder barrel constructed from cold drawn steel tubing in compliance to ASTM A513.
- High quality hard chrome plated and polished piston rod. Stainless steel piston rods are available on request.
- M3000 Series provides piping flexibility by 360 degrees rotatable rod end cap design, as well as a right-angled port option on the head end cap.
- The unique retainer connection on the M3000 rod end cap permits easier disassembly of the cylinder for simpler maintenance.
- S3000 Series employs screwed rod end cap design.
- The rod end cap design provides extra long piston rod support.
- Welded head end cap to barrel for strength.
- A wear ring on piston prevents direct piston-to-bore contact, ensuring longer service life.
- Rod wiper
- Clevis pins are supplied with each cylinder without extra costs.
- Boots and stop tubes are available on request.
- Non-standard stroke cylinders are available on request.

M3000 and S3000 Series

INSTALLATION DIMENSIONS

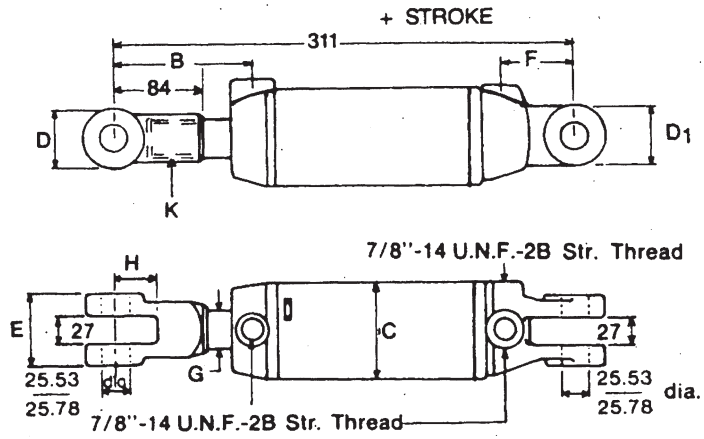

Bore Code X Stroke (MM)	A Closed Length mm	B mm	C mm	D mm	D1 mm	E mm	F m	G -Dia. K - Thread mm	H mm	Approx Mass kg					
20 x 203	514	136	60	64	54	67	65	25 3/4" - 16 UNF	41	6					
20 x 305	616									8					
20 x 406	717									9					
20 x 457	768									10					
20 x 610	921									12					
25 x 203	514	132	73					64		54	67	65	35 1"-12 UNF	41	8
25 x 305	616														10
25 x 406	717														11
25 x 457	768														13
25 x 610	921														15
30 x 203	514	129	87	64	54	67	65	35 1"-12 UNF	41	8					
30 x 305	616									13					
30 x 406	717									14					
30 x 457	768									16					
30 x 610	921									18					
35 x 203	514	129	100	64	54	67	65	44 1"-12 UNF	41	14					
35 x 305	616									16					
35 x 406	717									17					
35 x 457	768									19					
35 x 610	921									22					

CLEVIS PIN ASS'Y P/N 744405

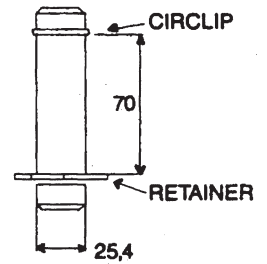
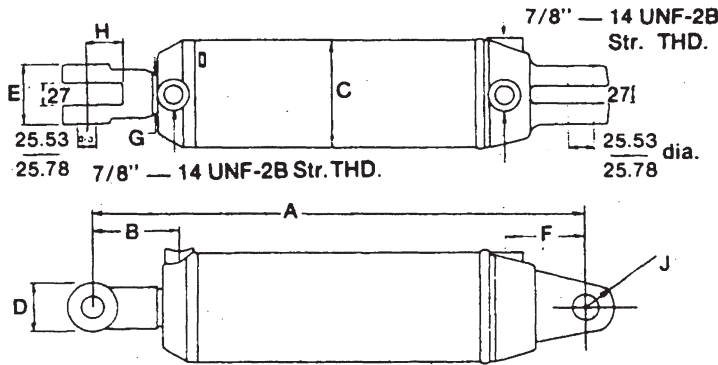

Cylinder prices include pins initially supplied

Bore Code X Stroke (MM)	A Closed Length mm	B mm	C mm	D mm	E mm	F mm	G -Dia. K - Thread mm	H mm	J mm	Approx Mass kg						
40 x 203	514	123	114	64	67	65	51 1-1/2" 12UNF	48	32R	22						
40 x 305	616									25						
40 x 406	717									27						
40 x 457	768									30						
40 x 610	921									35						
45 x 203	514	123	128							64	67	65	51 1-1/2" 12UNF	48	32R	25
45 x 305	616															29
45 x 406	717															31
45 x 457	768															34
45 x 610	921															40
50 x 203	514	123	143	64	67	65	51 1-1/2" 12UNF	48	32R	30						
50 x 305	616									34						
50 x 406	717									37						
50 x 457	768									41						
50 x 610	921									47						

S3000 SERIES SHOWING SCREWED ROD CAP

* Installation dimensions are identical for M3000 and S3000 Series.

** Rod end cap cannot be rotated with S3000 Series. Port orientation to be specified by model code.
(Refer to Model Code section on Page 6)

Code A : Ports 90 degrees to pin
Code B : Ports in line with pin

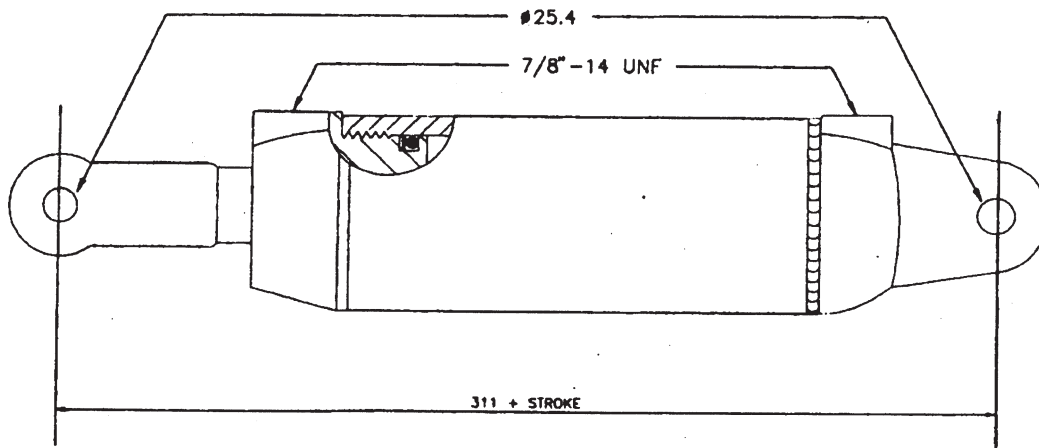

SEAL KITS AND SPARE PARTS

BORE DIAMETER	PART NUMBER (ORDER CODES)			
	SERIAL KIT	FEMALE CLEVIS *	FEMALE EYE	PIN PIVOT/COTTER
2" (50.8mm)	02-327142	02-327047	02-327048	744405*
2.5" (63.5mm)	02-327143	599685	455118	
3" (76.2mm)	02-327144		455119	
3.5" (88.9mm)	02-327145		455120	
4" (101.6mm)	02-327146	455344	455121	
4.5" (114.3mm)	02-327147		455122	
5" (127mm)	02-327146		455123	

* Pins are initially supplied with cylinders

** Consult your Eaton Fluid Power sales representative for other spares.

M3000 and S3000 Series

THEORETICAL PUSH AND PULL FORCES

PUSH FORCE AND DISPLACEMENT

CYLINDER BORE		PISTON ROD DIAMETER		PISTON AREA		CYLINDER PUSH STROKE FORCE AT VARIOUS PRESSURES										DISPLACEMENT PER cm/in OF STROKE	
						35 bar	500 psi	69 bar	1000 psi	103 bar	1500 psi	138 bar	2000 psi	207 bar	3000 psi	cm	in
mm	in	mm	in	sq.cm	sq.in	kN	lbf	kN	lbf	kN	lbf	kN	lbf	kN	lbf	litres	USgpm
50.8	2.0	25.4	1.0	20.27	3.14	6.98	1570	13.97	3140	20.95	4710	27.93	6280	41.90	9420	.02027	.0136
63.5	2.5	34.93	1.375	31.67	4.91	10.92	2455	21.84	4910	32.76	7365	43.68	9820	65.62	14730	.0317	.0213
76.2	3.0	34.93	1.375	45.62	7.07	15.74	3535	31.48	7070	47.17	11061	62.91	14140	94.39	21210	.0456	.0301
88.9	3.5	44.45	1.750	62.10	9.63	21.42	4815	42.85	9630	64.21	14445	85.64	19260	128.48	28890	.0621	.0345
101.6	4.0	50.80	2.0	81.07	12.57	27.96	6285	55.91	12570	83.87	18855	111.83	25140	167.74	37710	.0817	.0550
114.3	4.5	50.80	2.0	102.64	15.91	35.41	7955	70.82	15910	106.13	23865	141.54	31820	212.36	47730	.1026	.0689
127.0	5.0	50.80	2.0	126.68	19.64	43.68	9820	87.36	19640	131.04	29460	174.73	39280	262.09	58920	.1267	.0850

PULL FORCE AND DISPLACEMENT

CYLINDER BORE		PISTON ROD DIAMETER		ANNULUS AREA		CYLINDER PUSH STROKE FORCE AT VARIOUS PRESSURES										DISPLACEMENT PER cm/in OF STROKE	
						35 bar	500 psi	69 bar	1000 psi	103 bar	1500 psi	138 bar	2000 psi	207 bar	3000 psi	cm	in
mm	in	mm	in	sq.cm	sq.in	kN	lbf	kN	lbf	kN	lbf	kN	lbf	kN	lbf	litres	USgpm
50.8	2.0	25.4	1.0	15.20	2.36	5.25	1180	10.50	2360	15.75	3540	21.0	4720	31.49	7080	.0152	.01022
63.5	2.5	34.93	1.375	22.09	3.43	7.62	1715	15.24	3430	22.84	5145	30.46	6860	45.70	10290	.02209	.01484
76.2	3.0	34.93	1.375	36.03	5.59	12.43	2795	24.83	5583	37.25	8375	49.67	11167	74.5	16750	.0360	.0095
88.9	3.5	44.45	1.750	46.58	7.22	16.07	3608	32.10	7216	48.14	10824	64.19	14432	96.3	21648	.0466	.0123
101.6	4.0	50.80	2.0	60.80	9.43	20.96	4712	41.92	9425	62.88	14137	83.84	18850	125.8	28274	.0608	.0161
114.3	4.5	50.80	2.0	82.34	12.76	28.38	6381	56.77	12763	85.15	19144	113.5	25525	170.3	38288	.0823	.0218
127.0	5.0	50.80	2.0	106.41	16.49	36.68	8245	73.35	16490	110.03	24735	146.71	32980	220.05	49470	.10641	.07139

NOTE The push and pull forces listed above are only theoretical.
 When selecting a cylinder from this Catalogue, it is imperative that you analyze all aspects of your application, especially pressure reductions applicable to certain bore diameters and stroke length.

MODEL CODE

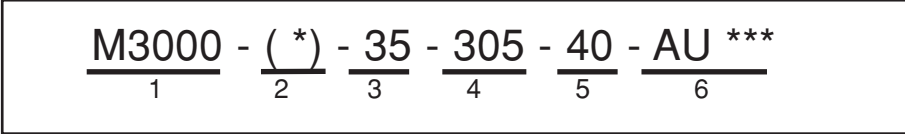

Code position

- 1: Cylinder Series
 M3000: M3000 Series (Retainer connected rod cap design)
 S3000: S3000 Series (Screwed rod end cap design)
- 2: Port orientation to pin (Code applicable to S3000 only, Omit for M3000)
 A: Ports 90 degrees to pin
 B: Ports in line with pin
- 3: Bore size code

20: 2" (50.8mm) 25: 2.5" (63.5mm) 30: 3" (76.2mm) 35: 3.5" (88.9mm) 40: 4" (101.6mm) 45: 4.5" (114.3mm) 50: 5" (127mm)		Available with S3000 Available with M3000
--	--	--
- 4: Stroke in mm
 Standard strokes ---- 203, 305, 406, 457, 610
- 5: Cylinder Design Code: Currently 40
- 6: Deviation (Special features): AU000 (Standard)

ORDER CODE (ASSEMBLY NUMBERS)

	**shows bore size code as per above
M3000 Series	3553** - stroke (in mm)
S3000 Series (port orientation code A)	1553** - stroke (in mm)
S3000 Series (port orientation code B)	2553** - stroke (in mm)

SMD Series

GENERAL DESCRIPTION

The Vickers SMD (Special Medium Duty) hydraulic linear actuators are suitable for a variety of applications on both mobile and industrial fields.

The compact design and simple but robust construction offer cost effective solutions, reliable operation and long service life.

The availability of various mounting style options, as well as tailored stroke length, allows the best selection to each application's requirements.

BASIC SPECIFICATIONS

Maximum pressure -----	210 bar (3000 psi)
Bore sizes -----	1.5", 2", 2.5", 3", 3.5", 4"
Strokes -----	To customer specification (see note below)

GRAPHICAL SYMBOL

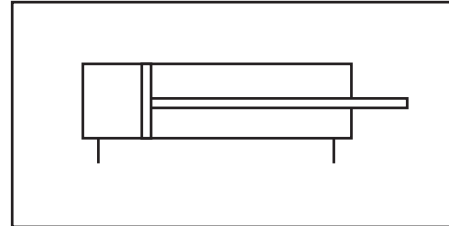

FEATURES

- Low cost units suitable for a wide range of mobile and industrial applications.
- 6 bore sizes from 1.5" to 4".
- 6 basic mounting style options for best selection to requirements.
- Tailored stroke length to requirements (see note below).
- Standard female clevises and female eyes.
- Cylinder barrel constructed from cold drawn steel tubing in compliance with ASTM A513.
- High quality hard chrome plated and polished piston rods.
- The rod end cap design and material used (High grade SG iron) provide extra long piston rod support, and excellent wear resistant characteristics.
- The piston wear ring prevents direct piston-to-bore contact, ensuring longer service life.

OPTIONAL FEATURES - AVAILABLE ON REQUEST

Stainless steel piston rods
Two pack epoxy paint
Special thread type and length on piston rods
Piston rod extension
Stop tube
Various other options - Consult Eaton Fluid Power Australia for availability

NOTE

When selecting a cylinder from the Catalogue and determining a stroke, it is imperative that all engineering aspects of your application are analyzed, especially for long stroke cylinders.

MOUNTING OPTIONS

NM – No Mount

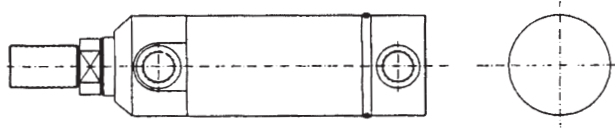

TTC – Tie Rod Tapping – Cap End

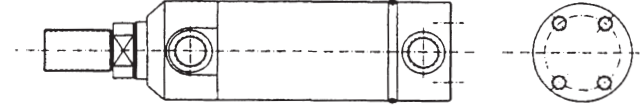

RFH – Rectangular Flange Head

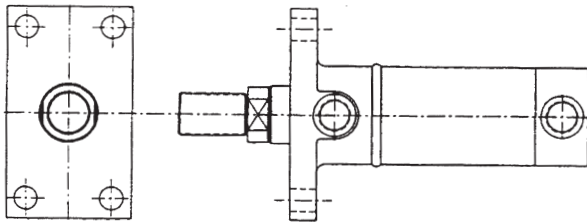

RFC – Rectangular Flange Cap

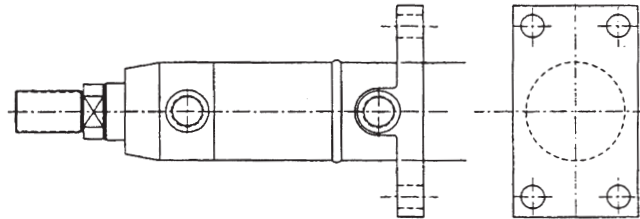

CFH – Circular Flange Head

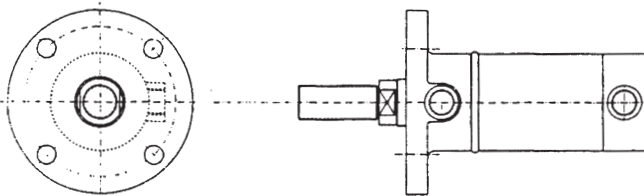

CFC – Circular Flange Cap

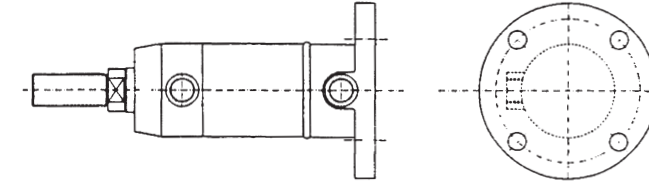

SMD Series

NM - NO MOUNT

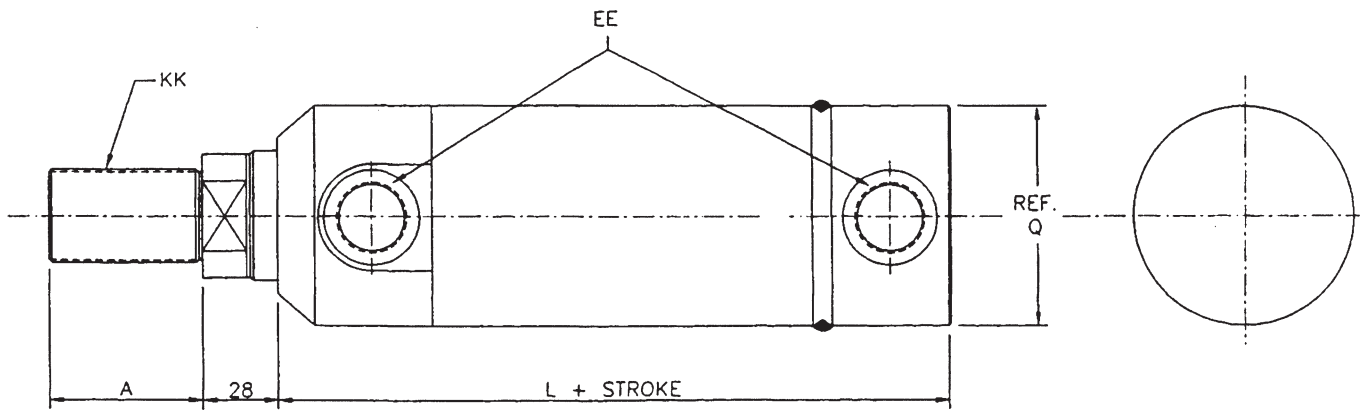

BORE DIA.	ROD DIA.	A	L	Q DIA.	KK	SAE O RING EE
38.1 (1.5")	25.4 (1.000")	25.4	143	51	0.750-16 UNF	0.562 UNF
50.8 (2.0")	28.6 (1.125")	25.4	143	61	0.750-16 UNF	0.750 UNF
63.5 (2.5")	34.9 (1.375")	34.9	143	76	1.000-14 UNF	0.875 UNF
76.2 (3.0")	38.1 (1.500")	34.9	143	90	1.000-14 UNF	0.875 UNF
88.9 (3.5")	44.5 (1.750")	44.5	143	102	1.250-12 UNF	0.875 UNF
101.6 (4.0")	50.8 (2.000")	44.5	154	118	1.500-12 UNF	0.875 UNF

TTC - TIE ROD TAPPING - CAP END

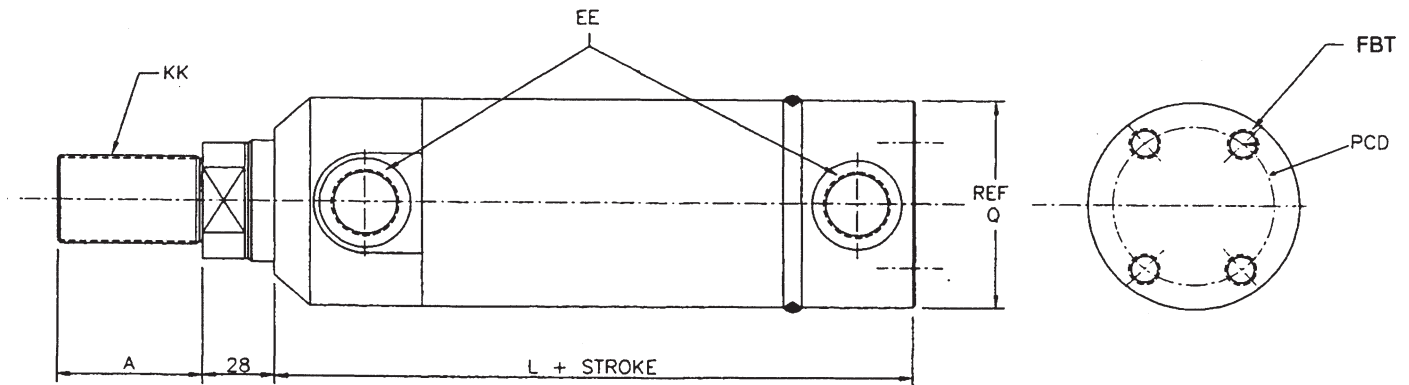

BORE DIA.	ROD DIA.	A	L	PCD	FBT THREAD	Q DIA.	KK	SAE O RING EE
38.1 (1.5")	25.4 (1.000")	25.4	143	38.1	3/8" - UNF	51	0.750-16 UNF	9/16" UNF
50.8 (2.0")	28.6 (1.125")	25.4	143	46.0	7/16" - UNF	61	0.750-16 UNF	3/4" UNF
63.5 (2.5")	34.9 (1.375")	34.9	143	57.2	1/2" - UNF	76	1.000-14 UNF	7/8" UNF
76.2 (3.0")	38.1 (1.500")	34.9	143	68.3	5/8" - UNF	90	1.000-14 UNF	7/8" UNF
88.9 (3.5")	44.5 (1.750")	44.5	143	77.8	5/8" - UNF	102	1.250-12 UNF	7/8" UNF
101.6 (4.0")	50.8 (2.000")	44.5	154	92.1	5/8" - UNF	118	1.500-12 UNF	7/8" UNF

NOTE: ● MOUNTING STUDS AVAILABLE ON REQUEST

**RFH - RECTANGULAR FLANGE - HEAD END
HOLE PATTERN TO NFPA STYLE MF1**

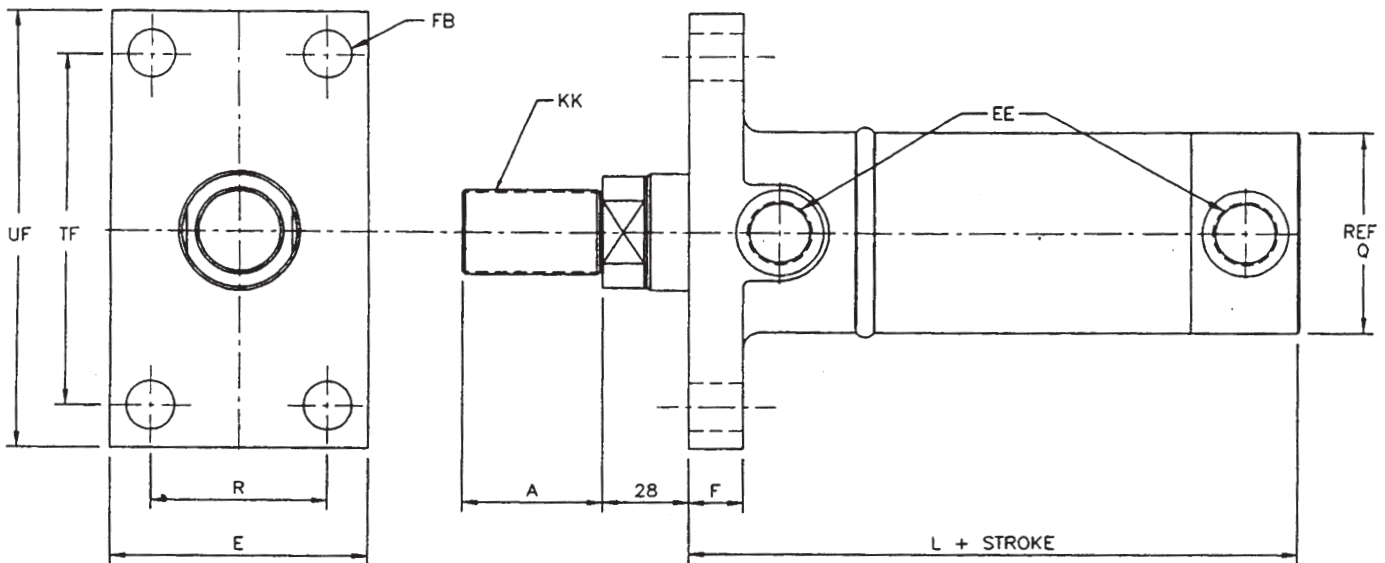

BORE DIA.	ROD DIA.	A	L	E	UF	R	TF	FB DIA.	F	Q DIA.	KK	SAE O RING EE
38.1 (1.5")	25.4 (1.000")	25.4	145	64	108	41.3	87.3	11.1	12.5	51	0.750-16 UNF	0.562 UNF
50.8 (2.0")	28.6 (1.125")	25.4	162	77	130	52.1	104.8	14.3	15.0	61	0.750-16 UNF	0.750 UNF
63.5 (2.5")	34.9 (1.375")	34.9	162	89	143	64.8	117.5	14.3	18.0	76	1.000-14 UNF	0.875 UNF
76.2 (3.0")	38.1 (1.500")	34.9	162	115	181	82.6	149.2	17.5	20.0	90	1.000-14 UNF	0.875 UNF
88.9 (3.5")	44.5 (1.750")	44.5	162	115	181	82.6	149.2	17.5	23.0	102	1.250-12 UNF	0.875 UNF
101.6 (4.0")	50.8 (2.000")	44.5	180	127	194	97.0	161.9	17.5	26.0	118	1.500-12 UNF	0.875 UNF

**RFC - RECTANGULAR FLANGE - CAP END
HOLE PATTERN TO NFPA STYLE MF2**

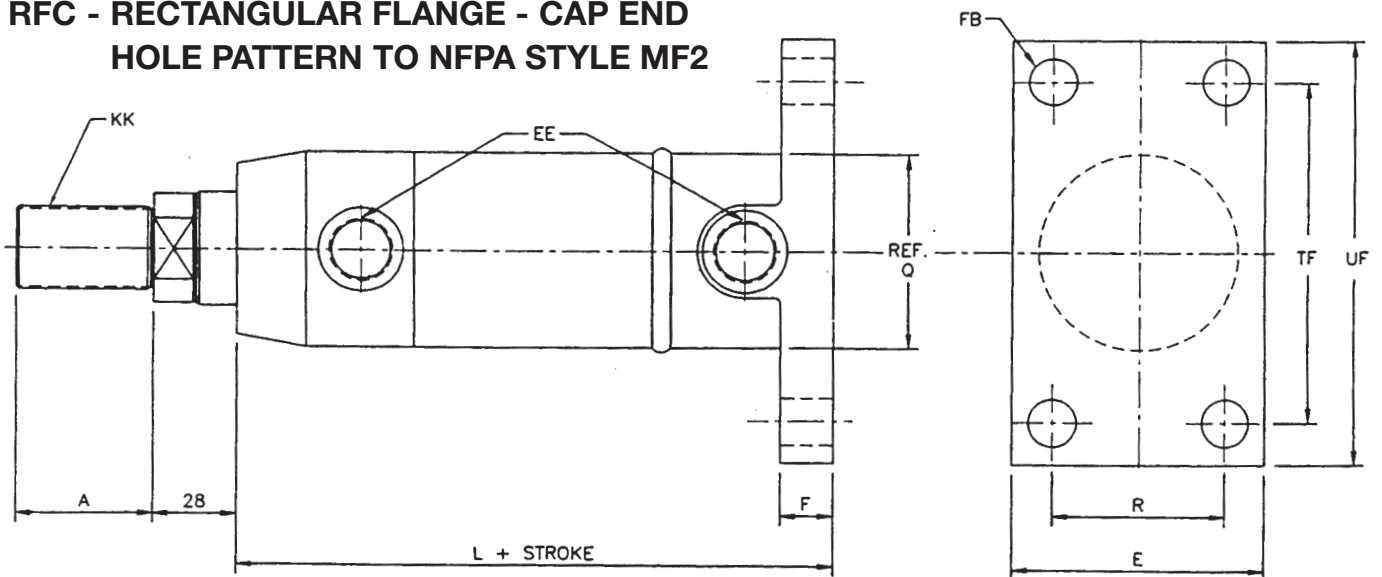

BORE DIA.	ROD DIA.	A	L	E	UF	R	TF	FB DIA.	F	Q DIA.	KK	SAE O RING EE
38.1 (1.5")	25.4 (1.000")	25.4	164	64	108	41.3	87.3	11.1	12.5	51	0.750-16 UNF	0.562 UNF
50.8 (2.0")	28.6 (1.125")	25.4	164	77	130	52.1	104.8	14.3	15.0	61	0.750-16 UNF	0.750 UNF
63.5 (2.5")	34.9 (1.375")	34.9	164	89	143	64.8	117.5	14.3	18.0	76	1.000-14 UNF	0.875 UNF
76.2 (3.0")	38.1 (1.500")	34.9	164	115	181	82.6	149.2	17.5	20.0	90	1.000-14 UNF	0.875 UNF
88.9 (3.5")	44.5 (1.750")	44.5	164	115	181	82.6	149.2	17.5	23.0	102	1.250-12 UNF	0.875 UNF
101.6 (4.0")	50.8 (2.000")	44.5	180	127	194	97.0	161.9	17.5	26.0	118	1.500-12 UNF	0.875 UNF

CFH - CIRCLE FLANGE - HEAD END

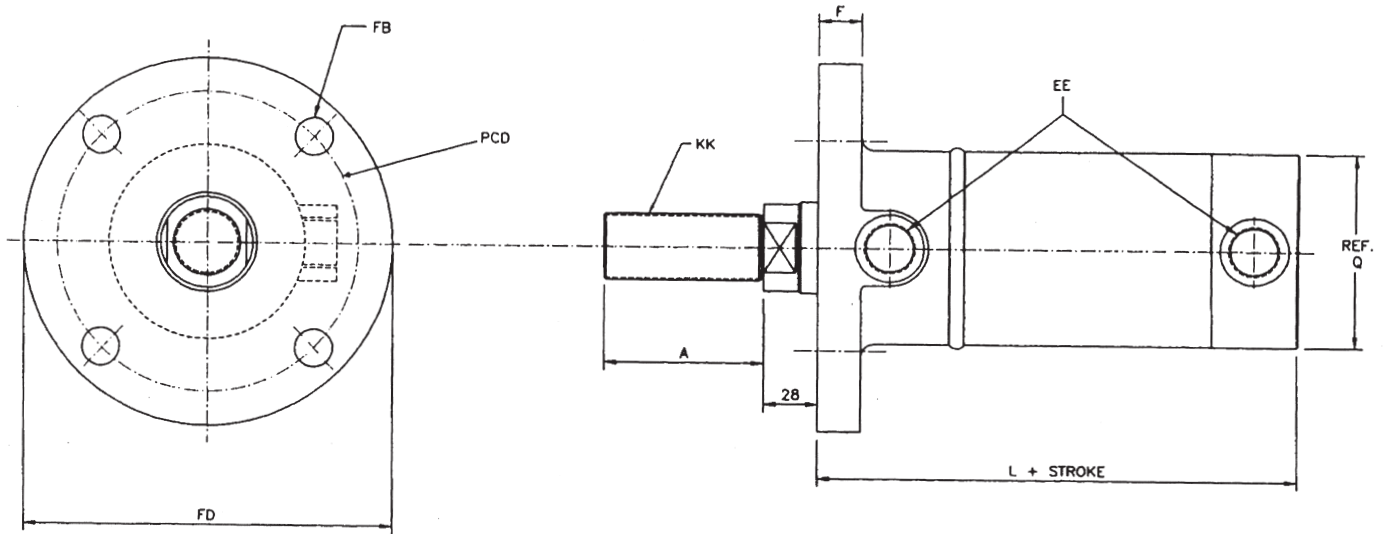

BORE DIA.	ROD DIA.	A	L	FD	PCD	FB DIA.	F	Q DIA.	KK	SAE O RING EE
38.1 (1.5")	25.4 (1.000")	25.4	145	100	76.2	11.1	11	51	0.750-16 UNF	0.562 UNF
50.8 (2.0")	28.6 (1.125")	25.4	162	115	88.9	14.3	14	61	0.750-16 UNF	0.750 UNF
63.5 (2.5")	34.9 (1.375")	34.9	162	130	101.6	14.3	16	76	1.000-14 UNF	0.875 UNF
76.2 (3.0")	38.1 (1.500")	34.9	162	155	120.7	17.5	18	90	1.000-14 UNF	0.875 UNF
88.9 (3.5")	44.5 (1.750")	44.5	162	165	133.4	17.5	22	102	1.250-12 UNF	0.875 UNF
101.6 (4.0")	50.8 (2.000")	44.5	180	195	152.4	20.5	24	118	1.500-12 UNF	0.875 UNF

CFC - CIRCLE FLANGE - CAP END

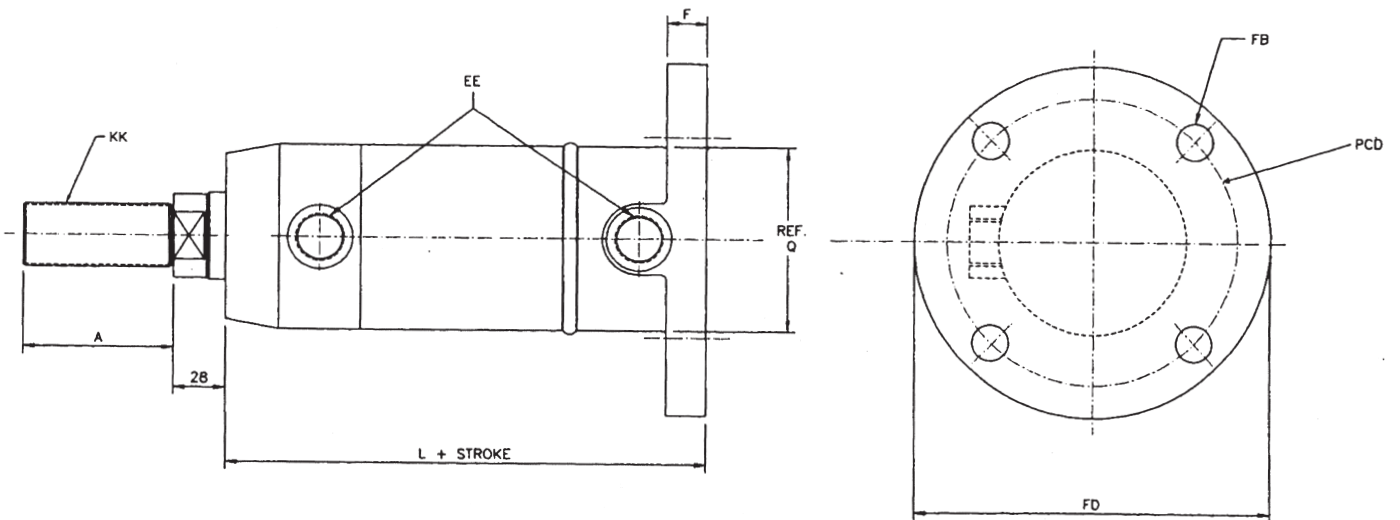

BORE DIA.	ROD DIA.	A	L	FD	PCD	FB DIA.	F	Q DIA.	KK	SAE O RING EE
38.1 (1.5")	25.4 (1.000")	25.4	164	100	76.2	11.1	11	51	0.750-16 UNF	0.562 UNF
50.8 (2.0")	28.6 (1.125")	25.4	164	115	88.9	14.3	14	61	0.750-16 UNF	0.750 UNF
63.5 (2.5")	34.9 (1.375")	34.9	164	130	101.6	14.3	16	76	1.000-14 UNF	0.875 UNF
76.2 (3.0")	38.1 (1.500")	34.9	164	155	120.7	17.5	18	90	1.000-14 UNF	0.875 UNF
88.9 (3.5")	44.5 (1.750")	44.5	164	165	133.4	17.5	22	102	1.250-12 UNF	0.875 UNF
101.6 (4.0")	50.8 (2.000")	44.5	180	195	152.4	20.5	24	118	1.500-12 UNF	0.875 UNF

ROD END ACCESSORIES

FEMALE CLEVIS

To achieve optimum cylinder performance and life female clevises and eyes have to be torqued against piston rod shoulder.

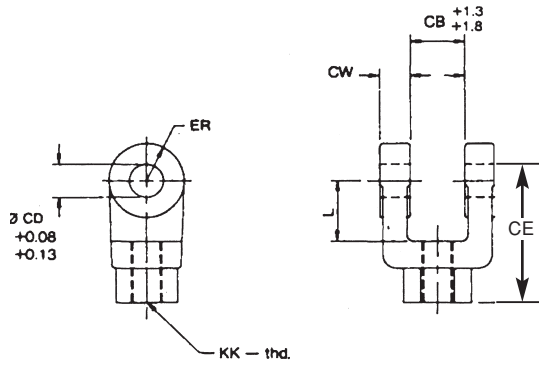

Dim.	PART No.	980909	980910	980911	980912
	CB	31.8	38.1	50.8	63.5
	CD \varnothing	19.05	25.4	34.93	44.45
	CE	60.3	79.4	104.8	114.3
	CW	15.9	19.1	25.4	31.8
	ER	19.1	25.4	35.1	44.5
	KKthd class 2	.750"-16	1.000"-14	1.250"-12	1.500"-12
	L	31.8	38.1	53.8	57.2
LOAD-kN max.		43.39	87.94	137.29	188.18

FEMALE EYE

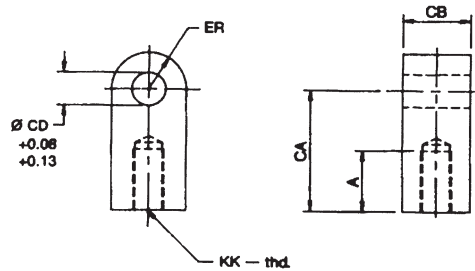

Dim.	PART No.	980901	980902	980903	980904
	A	30.0	42.7	51.0	57.2
	CA	52.4	71.4	87.3	101.6
	CB	31.8	38.1	50.8	63.5
	CD \varnothing	19.05	25.4	34.93	44.45
	ER	19.0	25.4	34.9	44.4
	KKthd class 2	.750"-16	1.000"-14	1.250"-12	1.500"-12
LOAD-kN max. 22.73		43.39	87.94	137.29	188.18

PIVOT PIN

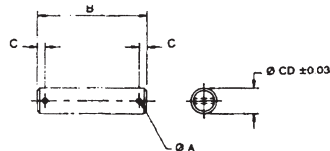

Dim.	PART No.	260684	260686	260687	260688
	A \varnothing	4.0	4.0	5.0	8.0
	B	85.1	98.6	127.8	158.0
	C	5.6	5.6	7.1	7.9
	CD \varnothing	19.05	25.40	34.93	44.45
LOAD-kN max.		65.6	111.00	203.53	329.63

SMD Series

MODEL CODE

SMD	-	TTC	-	35	-	305	-	40	-	AU	***
1		2		3		4		5		6	

Code position

- 1: Cylinder Series
 - SMD : Special Medium Duty Series
- 2 : Mounting Type (See Page 8 for overview)
 - NM : No Mount
 - TTC : Tie Rod Tapping on the cap end
 - RFH : Rectangular Flange Head
 - RFC : Rectangular Flange Cap
 - CFH : Circular Flange Head
 - CFC : Circular Flange Cap
- 3 : Bore size code
 - 14 : 1.5" (38.2mm)
 - 20 : 2.0" (50.8mm)
 - 25 : 2.5" (63.5mm)
 - 30 : 3.0" (76.2mm)
 - 35 : 3.5" (88.9mm)
 - 40 : 4.0" (101.6mm)
- 4 : Stroke in mm
- 5 : Cylinder Design Code : Currently 40
- 6 : Deviation (Special features) : AU000 (Standard)

SEAL KITS AND ACCESSORIES

* See Page 12 for dimension details.

BORE DIAMETER	PART NUMBERS (ORDER CODES)			
	SERIAL KIT	FEMALE CLEVIS *	FEMALE EYE	PIN* PIVOT/COTTER
1.5" (38.2mm)	02-327184	980909	980901	260684/471885
2.0" (50.8mm)	02-327417			
2.5" (63.5mm)	02-327143	980910	980902	260686/471888
3.0" (76.2mm)	02-327418			
3.5" (88.9mm)	02-327145	980911	980903	260687/471903
4.0" (101.6mm)	02-327146	980912	980904	260688/471925

Consult your Eaton Fluid Power sales representative for the availability of other accessories

Useful Hydraulic Formulas

THEORETICAL THRUST (CYLINDERS)	N =	Effective area (sq.cm) x pressure (bar) x10
	lb =	Effective area (sq.in) x pressure (psi)
HYDRAULIC POWER	kW=	$\frac{\text{Flow rate (lit/min) x pressure (bar)}}{600}$
	hp=	$\frac{\text{Flow rate (gpm x pressure (psi))}}{1714}$
GEOMETRIC FLOW RATE (CYLINDERS)	lit/min=	$\frac{\text{Effective area (sq.cm) x piston speed (m/min)}}{10}$
	gpm=	$\frac{\text{Effective area (sq.cm) x piston speed (in/min)}}{231}$
VELOCITY OF FLUID IN PIPE	m/sec=	$\frac{\text{Flow rate (lit/min) x 21.22}}{D \times D}$ (D : Inside diameter of pipe in mm)
	ft/sec=	$\frac{\text{Flow rate (gpm) x 0.408}}{D \times D}$ (D : Inside diameter of pipe in mm)

Conversion Factors

To convert \longrightarrow into \longleftarrow into

into ----- Multiply by the factor below
To convert ----- Multiply by the factor below

<u>Unit (Symbol)</u>	<u>Unit (Symbol)</u>	<u>Factor</u>
Inches (in)	Millimetres (mm)	25.4
Inches (in)	Centimetres (cm)	2.54
Inches (in)	Metres (m)	0.0254
Feet (ft)	Metres (m)	0.3084
Square inches (sq.in)	Square centimetres (sq.cm)	6.4516
Cubic inches (cu.in)	Cubic centimetres (cu.cm)	16.3871
Cubic inches (cu.in)	Litres (lit)	0.0163866
Pounds (lb) - mass	Kilograms (kg)	0.4536
Pounds per square inch (psi)	Bar (bar)	0.06894
Megapascals (MPa)	Bar (bar)	10
Horsepower (hp)	Kilowatts (kW)	0.7457
US Gallons (gal-US)	Litres (lit)	3.78531
Newtons/sq.centimetre (N/sq.cm)	Bar (bar)	0.1



Eaton Fluid Power Centres

(Vickers Systems Pty Ltd)
ABN 18 008 587 040

SUPPORT CENTRE

30 Rosamond Road, MARIBYRNONG, Victoria 3032 Australia
Postal Address: Private Bag 15, ASCOT VALE, Victoria 3032
Telephone: (03) 9319 8222 Fax: (03) 9318 5714

SYDNEY

47 Holbeche Road
ARNDELL PARK NSW 2148
Telephone: (02) 9671 0600 Fax: (02) 9671 0601

NEWCASTLE

17 Waterloo Avenue, THORNTON, N.S.W. 2322
Telephone: (02) 4966 8111 Fax: (02) 4966 8088

WOLLONGONG

9 Lady Penrhyn Drive, UNANDERRA, N.S.W. 2526
Telephone: (02) 4272 6366 Fax: (02) 4272 6377

ADELAIDE

3A CB Fisher Drive, Cavan, S.A. 5094
Telephone: (08) 8359 8920 Fax: (08) 8359 8915

BRISBANE

5/13 Murdoch Circuit,
ACACIA RIDGE, QLD 4110
Telephone: (07) 3712 6712 Fax (07) 3272 2677

MELBOURNE

1/30 Greens Road, DANDENONG, VIC. 3175
Telephone: (03) 9794 9299 Fax: (03) 9794 9992

PERTH

Unit 2/16-18 Kewdale Road,
WELSHPOOL, W.A. 6106
Telephone: (08) 9356 9711 Fax: 9356 9722

NEW ZEALAND

77-79 Ben Lomond Crescent
PAKURANGA, NEW ZEALAND
Telephone: 957 700 50 Fax: 957 658 65